

**READ ME FIRST**

**WALL SHEETING**

**ERECTION MANUAL**

**DUE TO THE PROCESS OF CONTINUOUS IMPROVEMENT,  
THE PRODUCTS AND PROCEDURES IN THIS MANUAL ARE  
SUBJECT TO CHANGE WITHOUT NOTICE**

Part # H8300

# 1.0 TABLE OF CONTENTS

<b>1.0</b>	<b>TABLE OF CONTENTS</b> .....	<b>2</b>
<b>1.0</b>	<b>RECEIVING, HANDLING, AND STORING MATERIALS</b> .....	<b>3</b>
1.1	Receiving Materials & Filing Claims.....	3
1.2	Handling Materials.....	4
1.3	Storing Materials.....	5
<b>2.0</b>	<b>PANEL PROFILES</b> .....	<b>6</b>
<b>3.0</b>	<b>STANDARD PARTS</b> .....	<b>7</b>
<b>4.0</b>	<b>PROPER FASTENER INSTALLATION</b> .....	<b>9</b>
<b>5.0</b>	<b>PANEL PREPARATION</b> .....	<b>11</b>
5.1	Pre-Drilling Panels.....	11
5.2	Important Information About Wall Panel Orientation.....	12
5.3	Wall Panel Erection Notes.....	13
<b>6.0</b>	<b>BASE TRIM INSTALLATION</b> .....	<b>14</b>
6.1	Standard Base Angle Trim.....	14
6.2	Optional Base Trim.....	15
<b>7.0</b>	<b>FASTENER REQUIREMENTS FOR EACH PANEL TYPE</b> .....	<b>16</b>
7.1	Fastener requirements for "CLASSIC" Wall Panel.....	16
7.2	Fastener Requirements for "ACCENT" Wall Panel.....	17
7.3	Fastener Requirements for "REVERSE CLASSIC" Wall Panel.....	18
7.4	Proper Fastener Sequence Detail.....	19
<b>8.0</b>	<b>FRAMED OPENING TRIM INSTALLATION</b> .....	<b>21</b>
8.1	Panel Preparation at Head Trim.....	21
8.2	Head Trim Installation.....	22
8.3	Standard Jamb Trim Installation.....	23
8.4	"Reverse Classic" Panel Jamb Trim Installation.....	24
<b>9.0</b>	<b>CORNER TRIM INSTALLATION</b> .....	<b>25</b>
9.1	"CLASSIC" Panel.....	25
9.2	"ACCENT" Panel.....	26
9.3	"REVERSE CLASSIC" Panel.....	27

## 1.0 RECEIVING, HANDLING, AND STORING MATERIALS

### 1.1 RECEIVING MATERIALS & FILING CLAIMS

- Check shipment against delivery tickets during unloading.
  - Note any damage or discrepancies on the delivery tickets before signing as receiver.
  - **The Metal Building Supplier** is not responsible for carrier damage or discrepancies not noted on the delivery tickets.
  - **The Metal Building Supplier** is not responsible for items accepted in questionable condition.
- Upon acceptance of shipment(s), the **contractor** is responsible for the proper storage and handling of materials as described in this manual.
  - The customer assumes full responsibility for the condition of this material after deliver by the trucking company.
  - **The Metal Building Supplier** is not responsible for injury, damage, or loss as a result of improper storage and/or handling.
  - All claims must be filed with the **Metal Building Supplier's Quality Services Representative** prior to any field modifications or purchases that may result in a charge to the **Metal Building Supplier**.

THIS BUILDING IS DESIGNED, MANUFACTURED, AND DELIVERED IN ACCORDANCE WITH THE 2006 M.B.M.A. METAL BUILDING SYSTEMS MANUAL. CONSULT THE INFORMATION IN THE "COMMON INDUSTRY PRACTICES" SECTION.

## 1.2 HANDLING MATERIALS

Wall panels are rolled and banded, with a cover panel placed top and bottom.

Panel bundle weight can be found on i.d. tag at low end of each bundle. Maximum weight is 4300 pounds.

Bundles up to 25 feet can be handled using a forklift. Forks must be spaced a minimum of five feet apart.

Bundles over 25 feet should be handled with a crane using a spreader bar and nylon slings. Lifting should occur at center of gravity.

Locate slings at 1/4 of the length of the panel from each end of the bundle.

Trim crates/boxes are to be handled the same as panel bundles.

**STEEL CHOKERS/SLINGS, CABLES OR CHAINS SHALL NOT BE USED.**

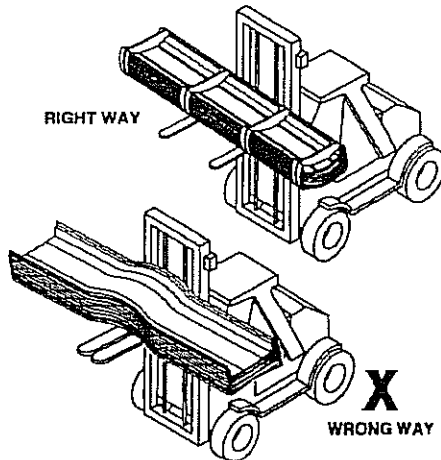
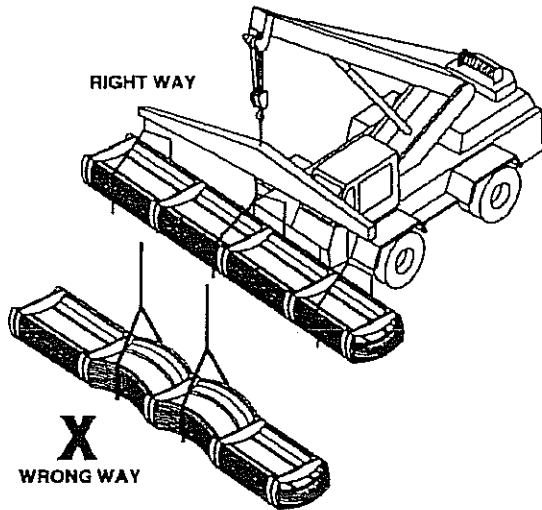

### 1.3 STORING MATERIALS

Panel and trim bundles / crates should be blocked 12 inches above grade.

Elevate one end to allow moisture to drain.

Loosely cover with waterproof tarp to allow proper air circulation.

Inspect daily and dry if necessary.

Accessories must be kept dry and free of contamination. Store indoors if possible.

**If the panels are wet**, the bundles should be opened and then the panels should be dried and re-stacked to prevent damage.

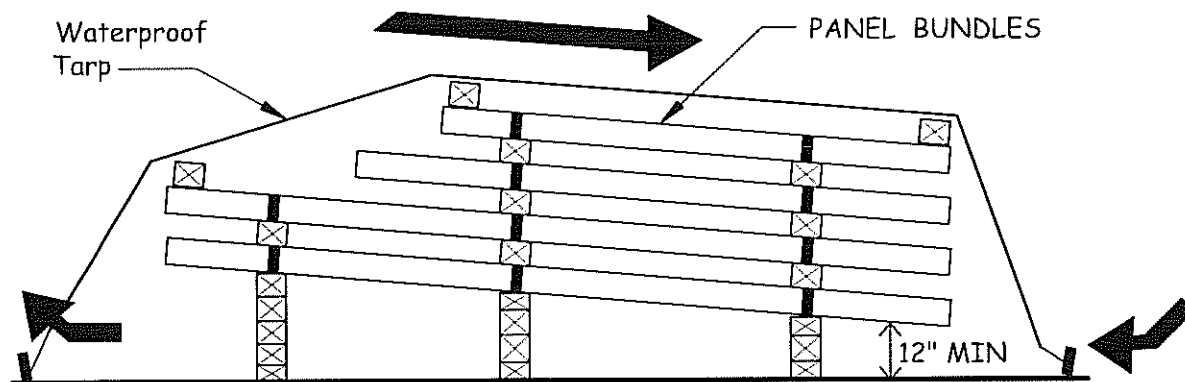
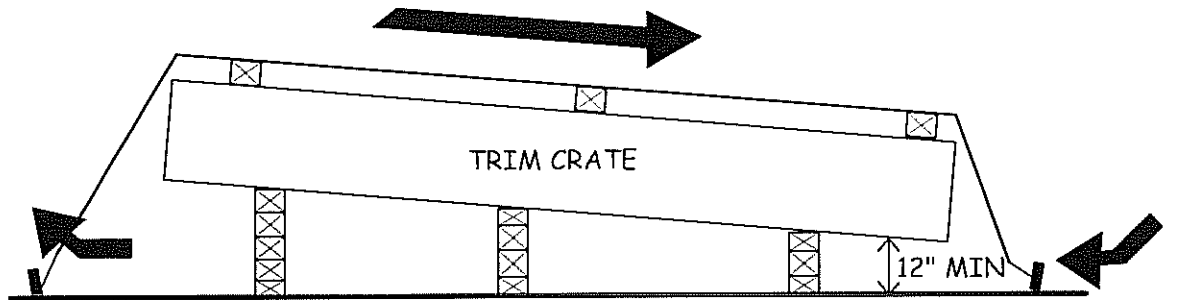

## 2.0 PANEL PROFILES

### PART NUMBERING CONVENTIONS

Example: CW E 01 x 122.50

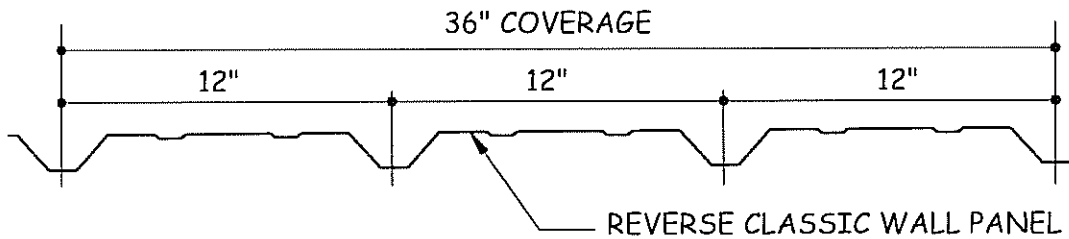
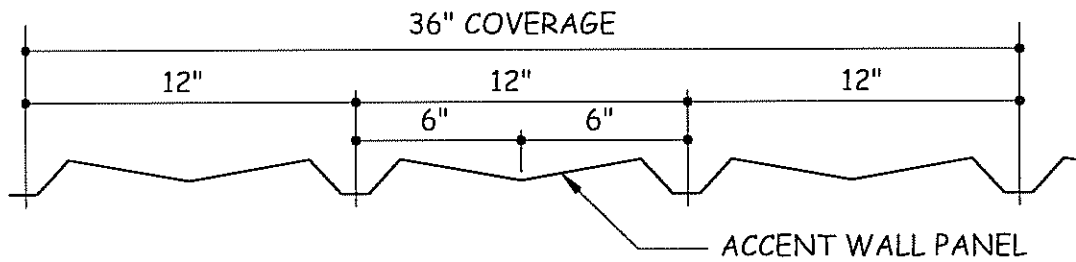
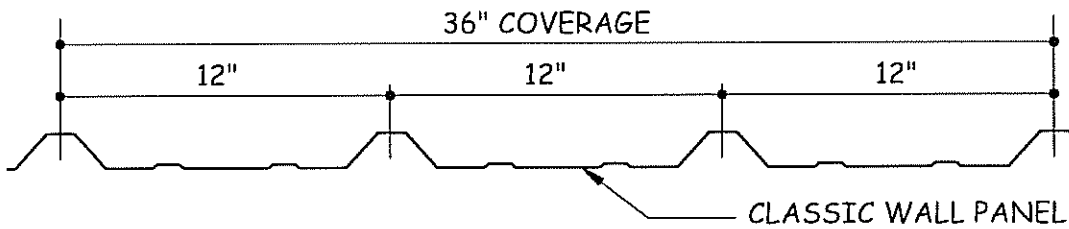
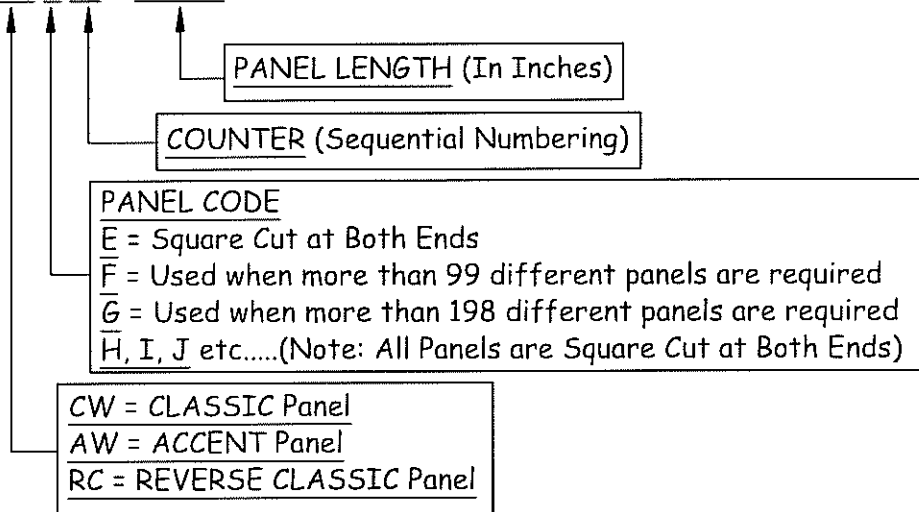

### 3.0 STANDARD PARTS

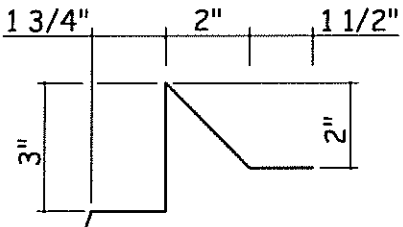
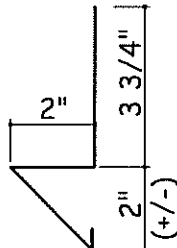
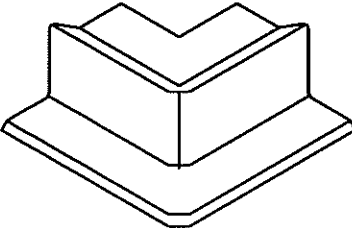
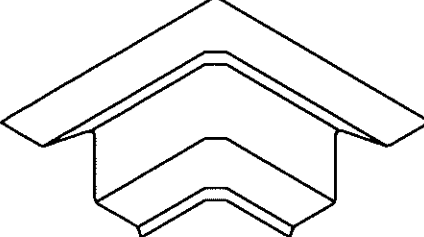
<p><u>ONE PIECE BASE TRIM</u> 18 Gauge Steel</p>  <p>Part Numbers BSA01 x 10'-1" BSA02 x 20'-2"</p>	<p><u>TWO PIECE BASE TRIM</u> 26 Gauge Steel</p>  <p>Part No. BS01</p>
<p><u>PLASTIC OUTSIDE CORNER</u> (For One Piece Base Trim)</p>  <p>Part No. H4140</p>	
<p><u>PLASTIC INSIDE CORNER</u> (For One Piece Base Trim)</p>  <p>Part No. H4150</p>	

**HEAD TRIM**

26 Gauge Steel

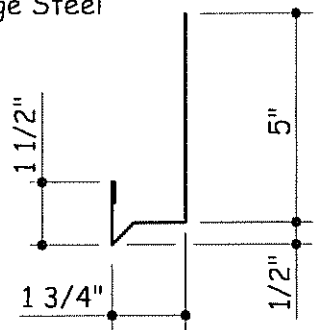

Part No. HTA\_\_

**JAMB TRIM**

For Classic and Accent Panel  
26 Gauge Steel

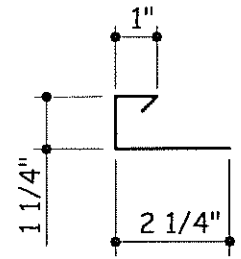

Part No. JTA\_\_

**JAMB TRIM**

For Reverse Classic Panel  
26 Gauge Steel

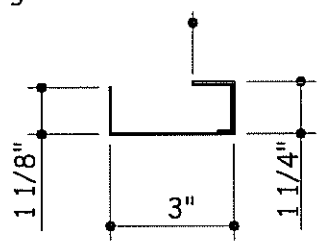

Part No. JTD\_\_

**SILL TRIM**

26 Gauge Steel

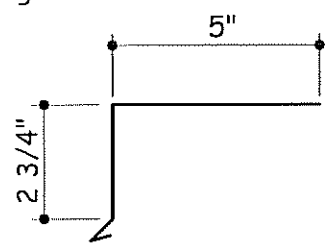

Part No. STA\_\_

**JAMB COVER TRIM**

26 Gauge Steel

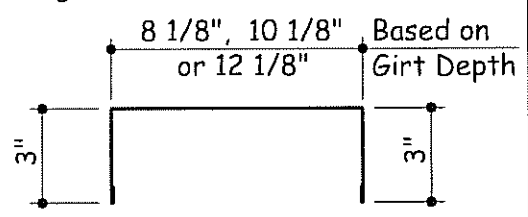

Part Numbers  
 CCA01-8" Girts  
 CCB01-10" Girts  
 CCC01-12" Girts

**PLASTIC DOOR END CLOSURE**

(For Optional Base Trim at F. O.'s)  
Left and Right Part included as shown

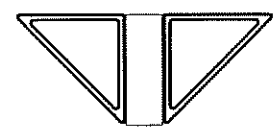

Part No. H4220



## 4.0 PROPER FASTENER INSTALLATION

### SEE THE FASTENER SCHEDULE BELOW

#### RECOMMENDED TOOL TYPES:

2000 - 2500 rpm screw gun with torque adjustable clutch

Manual or electric rivet tool

6-7 amp or higher rated tools (**DO NOT USE CORDLESS SCREW GUNS**)

#### DO NOT USE IMPACTING TOOLS

To assure proper voltage to the tool, extension cords should be checked for proper wire size/chord length.

16 gage wire, maximum chord length = 100'

14 gage wire, maximum chord length = 200'

12 gage wire, maximum chord length = 300'

#### DRIVING TIPS:

Drive fasteners perpendicular to panel surface

Compress the insulation at fastener location with one hand while driving the fastener with the other. This will help keep the panel flat and prevent the fastener from "walking".

Excessive pressure can cause drill point failure. Let the fastener do the work.



**IMPORTANT NOTE:** NOSE CONES SHOULD BE USED ON SCREW GUNS TO PREVENT DISTORTING THE PANEL AND TO HELP AVOID OVER-DRILLING THE FASTENERS.

#### FASTENER SEQUENCE

FASTENERS SHOULD BE INSTALLED FROM THE BASE TO THE EAVE. This will help prevent the panels from oil-canning. See section 7.4 for detail.

#### FIELD CUTTING OF PANELS:

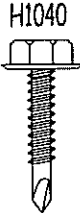
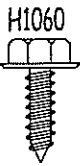
When field cutting or mitering "Classic"™ roof panels, non-abrasive cutting tools such as nibblers or tin-snips shall be used. Abrasive cutting tools such as mechanical grinders, saws, shears, or scissors can damage the galvalume finish and create excess metal shavings that can corrode the panels. The use of non-approved cutting devices may void the factory warranty.

FASTENER	SPECIFICATIONS	USAGE
 <p>H1040</p>	<p>SELF-DRILLING SCREW No. 12-14x1 1/4" TEK 2 W/O Washer 5/16" HEAD</p> <p>Recommended Tool Types: -2000-2500 RPM; Torque Adjustable Clutch -DO NOT use Impacting Tools</p>	<p>Used attach wall panel, wall flashing and light gage parts. Maximum Insulation thickness is 6".</p>
 <p>H1060</p>	<p>SELF-TAPPING SCREW No. 12-14x 3/4" Sharp Point W/O Washer. 5/16" HEAD</p> <p>Recommended Tool Types: -2000 RPM; Torque Adjustable Clutch -DO NOT use Impacting Tools</p>	<p>Used to attach light gage wall trim end laps and trim to wall panels.</p>
 <p>H1100</p>	<p>POP RIVET 1/8" Blind Pop Rivet</p> <p>Recommended Tool Types: -Manual or Electric Rivet Tool -DO NOT use Impacting Tools</p>	<p>Used at trim laps, corner caps, and attaching lightgage material to siding where stitch screws can't be used.</p>



## 5.0 PANEL PREPARATION

### 5.1 PRE-DRILLING PANELS

PRE-DRILLING OF SIDELAP JOINTS IS RECOMMENDED, WHICH IN MANY CASES, WILL SPEED ERECTION AND MAKE A TIGHT JOINT.

**STEP 1:** Stack panels with ends flush on a level place on the ground in piles not exceeding 10 panels. Then place small wooden blocks under side lapping edge of stack of panels to hold them at correct height and position while drilling screw holes. Hold panels tightly together at each end with "Vise Grip Pliers". Carefully mark positions for sidelap fasteners on top of high rib. Fasteners should be located "ON CENTER" of high rib AS SHOWN BELOW.

**STEP 2:** Drill holes for "Stitch" screws (Use #1,-7/32"-15/64" drill-bit) on top sheet of sidelap. Be sure panels are well nested before drilling.

**WHEN USING OTHER TYPE FASTENERS, SIZE OF DRILL-BIT MAY CHANGE!**

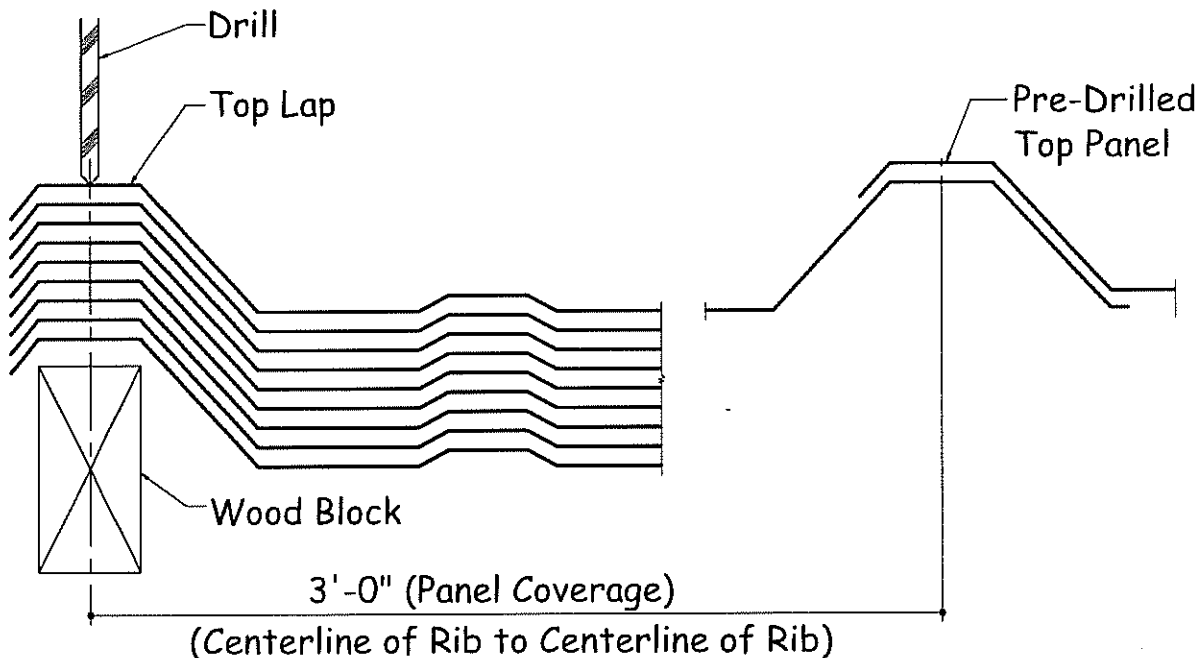

5.2 IMPORTANT INFORMATION ABOUT WALL PANEL ORIENTATION

"ACCENT" and "REVERSE CLASSIC" wall panels are "HANDED" panels. The "UPTURNED" leg of the panel ALWAYS goes on the bottom. See the details below.

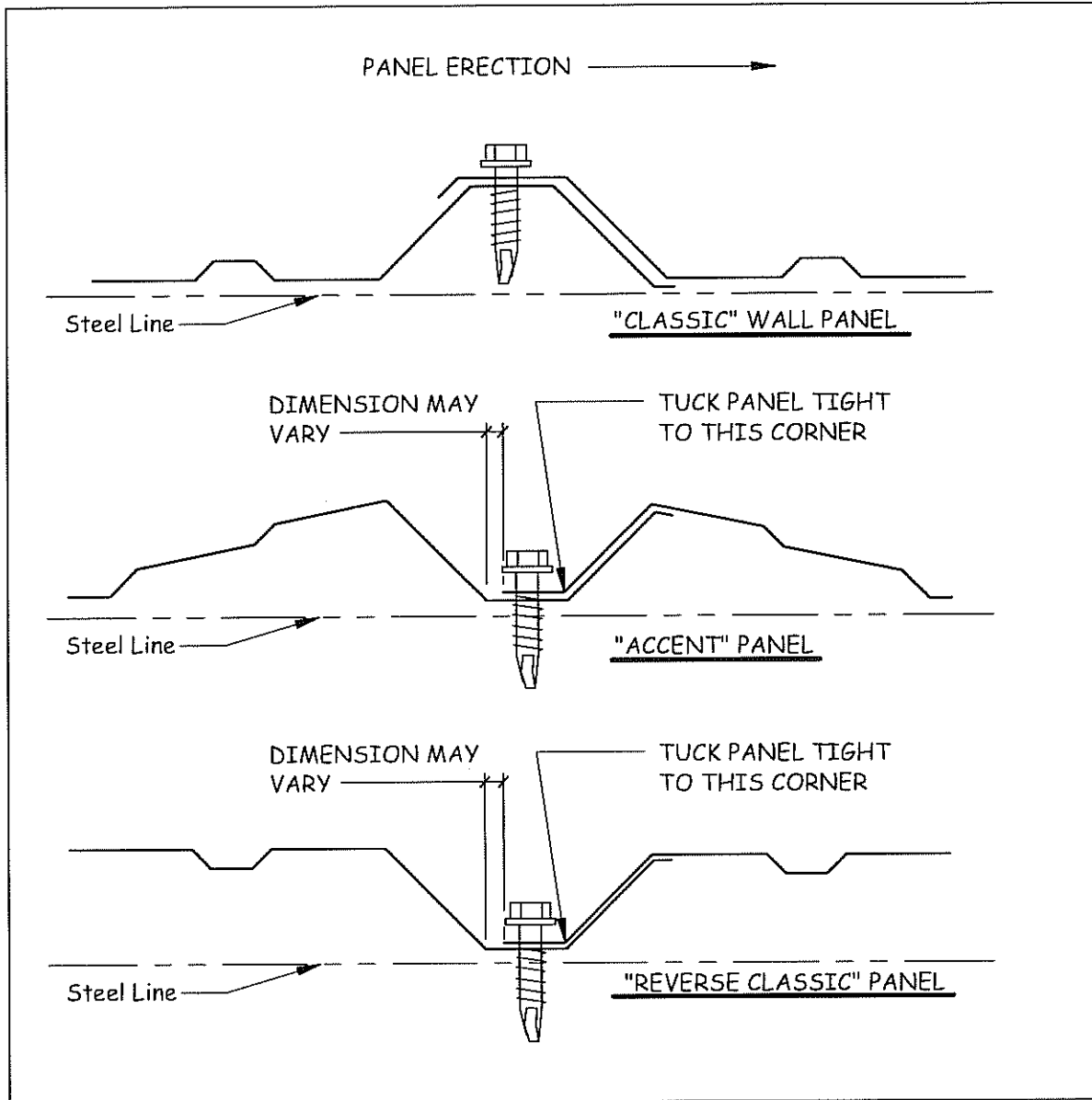

### 5.3 WALL PANEL ERECTION NOTES

- **Block girts to “level” position before starting panel erection.** Keep this blocking (blocking is not provided by the Metal Building Supplier) in place until the wall panel to girt fasteners are installed.
- Make sure that the first wall panel is **aligned and plumb.**
- To prevent “Oil-Canning”, **all panel fasteners should start from the base** and then be fastened to each girt location working toward the eave
- Make sure that the foundation is **square, level, and correct** to the out-to-out steel line dimensions.
- The erection crew is responsible for **cleaning all wall panels** before leaving the job site.
- Prevailing wind, main traffic area, etc. should be taken into consideration when sheeting the wall.
- **Panels must be stored properly to prevent moisture damage.** Reference section 1.3 for additional information.

## 6.0 BASE TRIM INSTALLATION

### 6.1 STANDARD BASE ANGLE TRIM

At Standard Base Angle Trim laps, apply a bead of **polyurethane tube caulk** (H3152) to all adjoining surfaces and lap 1".

**INSULATION HINT:** At the base, fold the insulation backer over the fiber to help prevent water from wicking.

See the erection drawing details for base trim corner termination parts numbers.

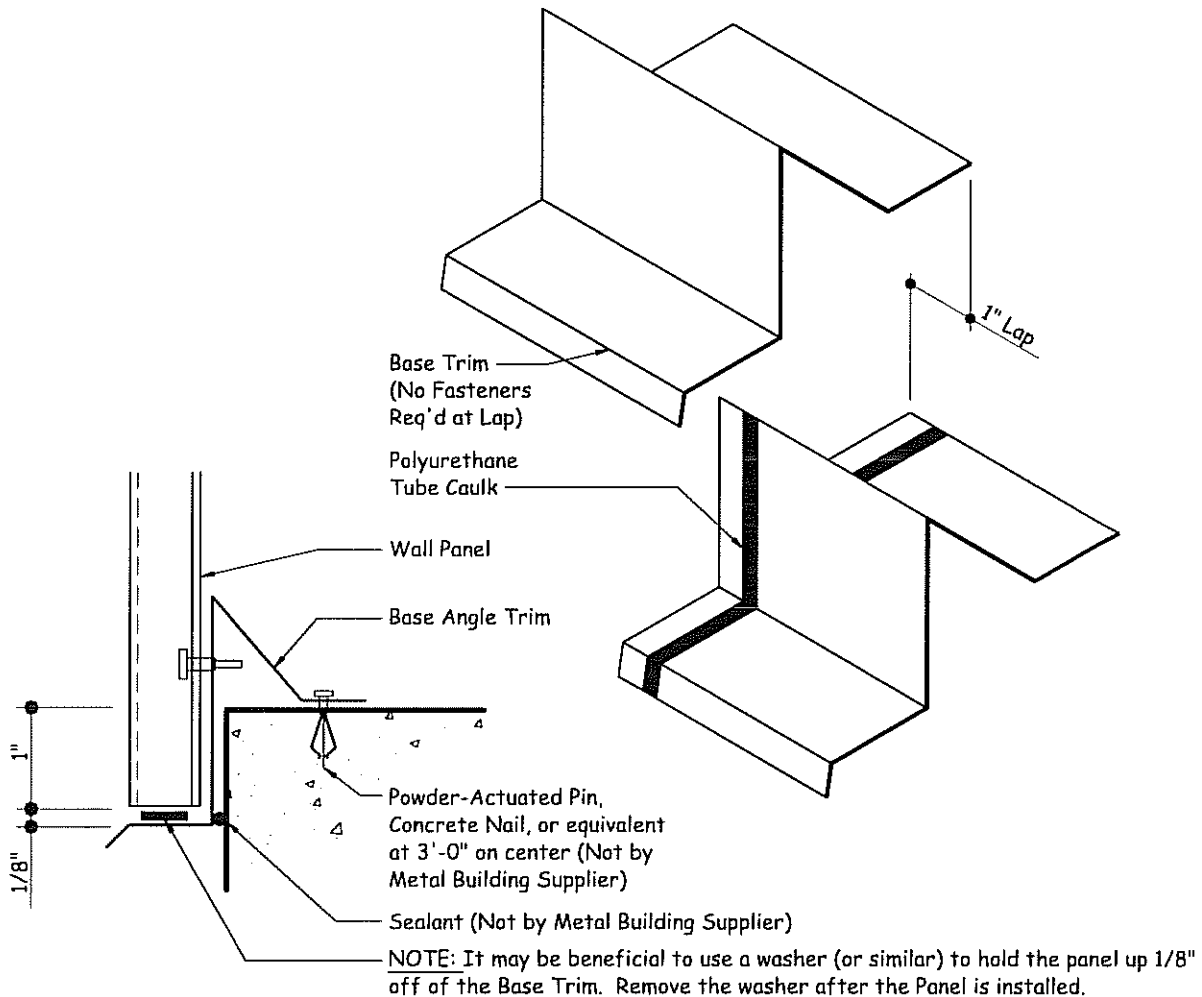

## 6.2 OPTIONAL BASE TRIM

Before lapping trim, field cut the back vertical leg of the adjoining trim piece 1" as shown below. This will help to make the trim lap more readily.

At Optional Base Trim laps, apply a bead of **polyurethane tube caulk (H3152)** to all adjoining surfaces and lap 1".

See the erection drawing details for base trim corner termination parts numbers.

**INSULATION HINT:** At the base, fold the insulation backer over the fiber to help prevent water from wicking.

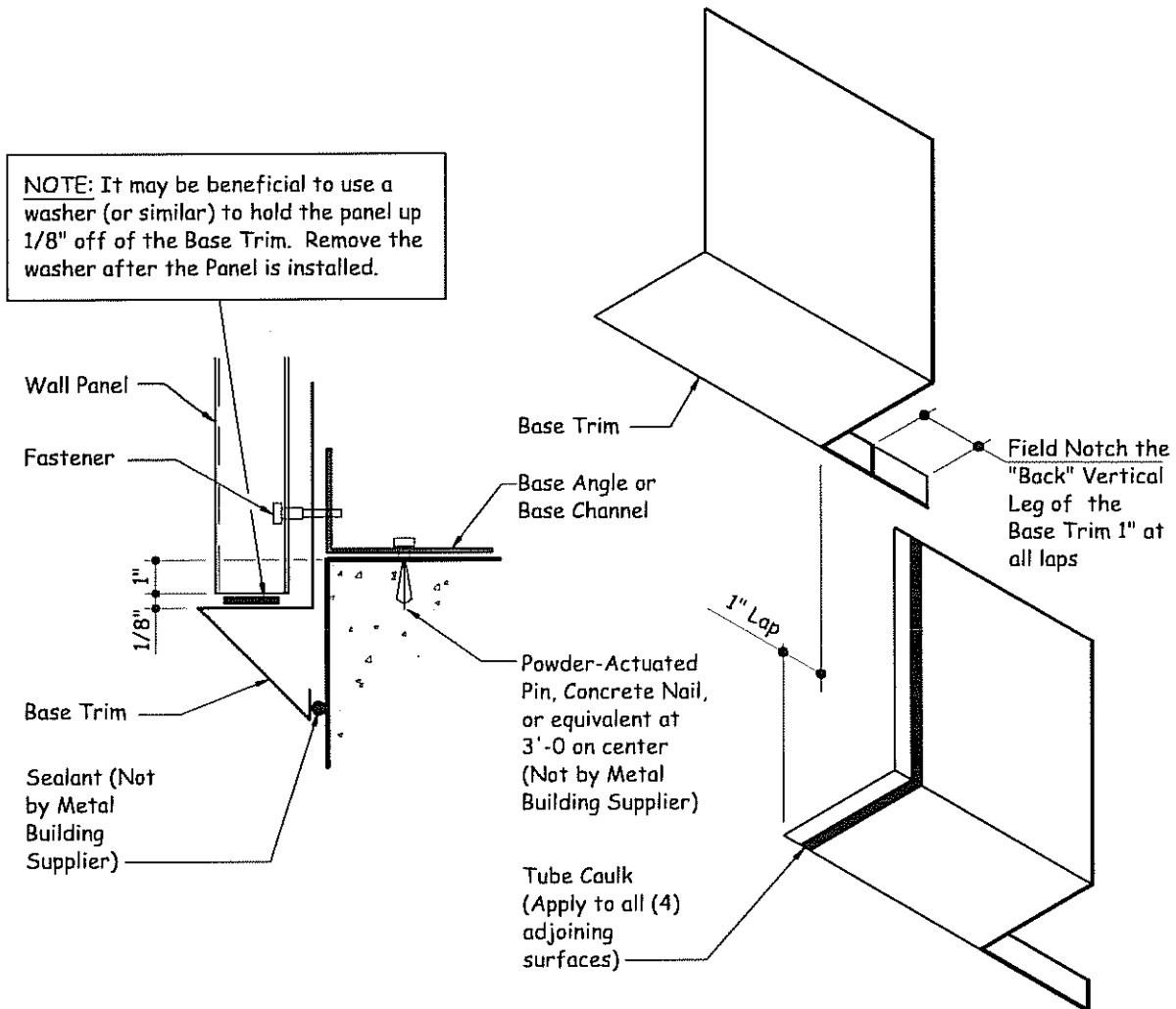

## 7.0 FASTENER REQUIREMENTS FOR EACH PANEL TYPE

### 7.1 FASTENER REQUIREMENTS FOR "CLASSIC" WALL PANEL

NOTE: USE NOSE CONES ON SCREW GUNS TO PREVENT DISTORTING THE PANEL AND TO HELP AVOID OVER-DRIVING THE FASTENERS

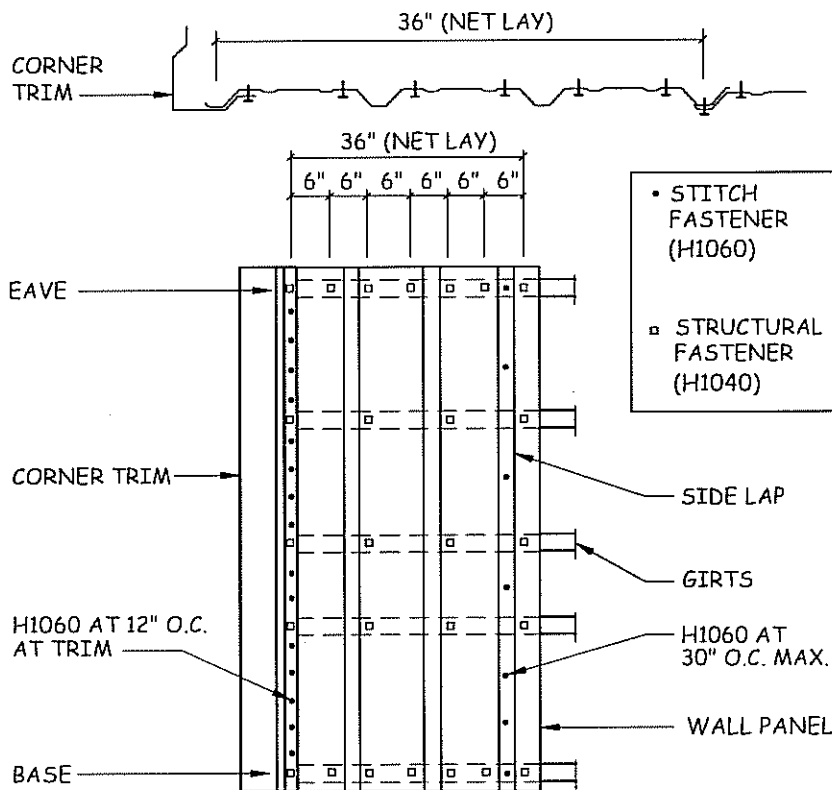

## "CLASSIC" WALL ERECTION NOTES

ERECTOR NOTE: 1/2" SIDELAP MASTIC (H3010) IS REQ'D IN SNOWDRIFT CONDITIONS. REFER TO THE ELEVATIONS FOR LOCATION REQUIREMENTS.

### CLASSIC PANEL

Fasten to base and eave structural members with 12-14 x 1 1/4" tek 2 structural fasteners (H1040) at 6" o.c. (next to each rib)

Fasteners to intermediate structural members with 12-14 x 1 1/4" tek 2 structural fasteners (H1040) at 12" o.c. (3" each side of rib)

Fasten sidelaps with 12-14 x 3/4" sharp point screws (H1060):  
 - At girts  
 - 30" o.c. between supports

Fasten trim with 12-14 x 3/4" sharp point screws (H1060) at 12" O.C.



7.2 **FASTENER REQUIREMENTS FOR "ACCENT" WALL PANEL**

NOTE: USE NOSE CONES ON SCREW GUNS TO PREVENT DISTORTING THE PANEL AND TO HELP AVOID OVER-DRIVING THE FASTENERS

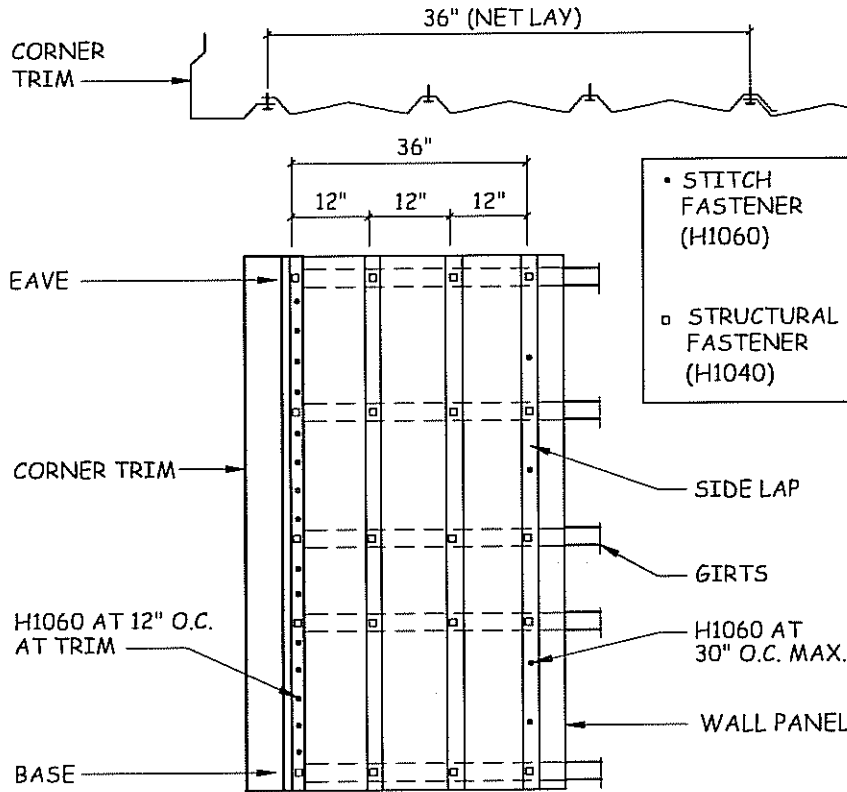

**"ACCENT" WALL ERECTION NOTES**

ERECTOR NOTE: 1/2" SIDELAP MASTIC (H3010) IS REQ'D IN SNOWDRIFT CONDITIONS. REFER TO THE ELEVATIONS FOR LOCATION REQUIREMENTS.

**ACCENT PANEL:**

Fasten structural members with 12-14 x 1 1/4" tek 2 structural fasteners (H1040) at 12" o.c. (in each rib)

Fasten sidelaps with 12-14 x 3/4" sharp point screws (H1060):  
 - At girts  
 - 30" o.c. between supports

Fasten trim with 12-14 x 3/4" sharp point screws (H1060) at 12" O.C.

7.3 FASTENER REQUIREMENTS FOR "REVERSE CLASSIC" WALL PANEL

NOTE: USE NOSE CONES ON SCREW GUNS TO PREVENT DISTORTING THE PANEL AND TO HELP AVOID OVER-DRIVING THE FASTENERS

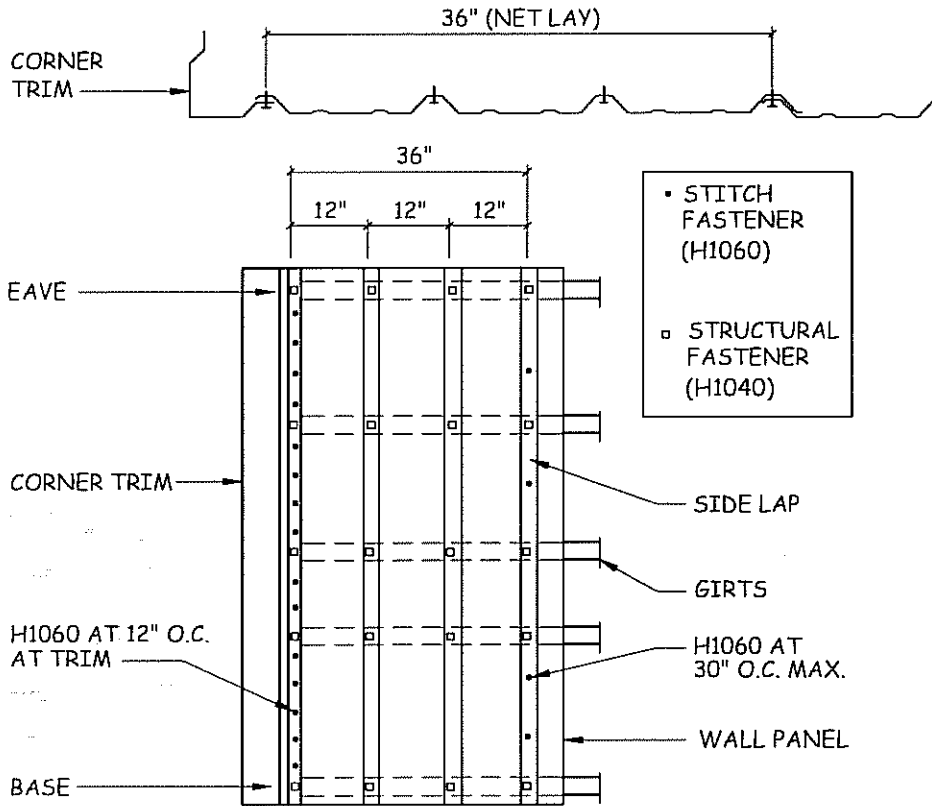

**"REVERSE CLASSIC" WALL ERECTION NOTES**

ERECTOR NOTE: 1/2" SIDELAP MASTIC (H3010) IS REQ'D IN SNOWDRIFT CONDITIONS. REFER TO THE ELEVATIONS FOR LOCATION REQUIREMENTS.

<b>REVERSE CLASSIC PANEL:</b>	
Fasten structural members with 12-14 x 1 1/4" tek 2 structural fasteners (H1040) at 12" o.c. (in each rib)	Fasten sidelaps with 12-14 x 3/4" sharp point screws (H1060): - At girts - 30" o.c. between supports
	Fasten trim with 12-14 x 3/4" sharp point (H1060) screws at 12" o.c.

7.4 **PROPER FASTENER SEQUENCE DETAIL**

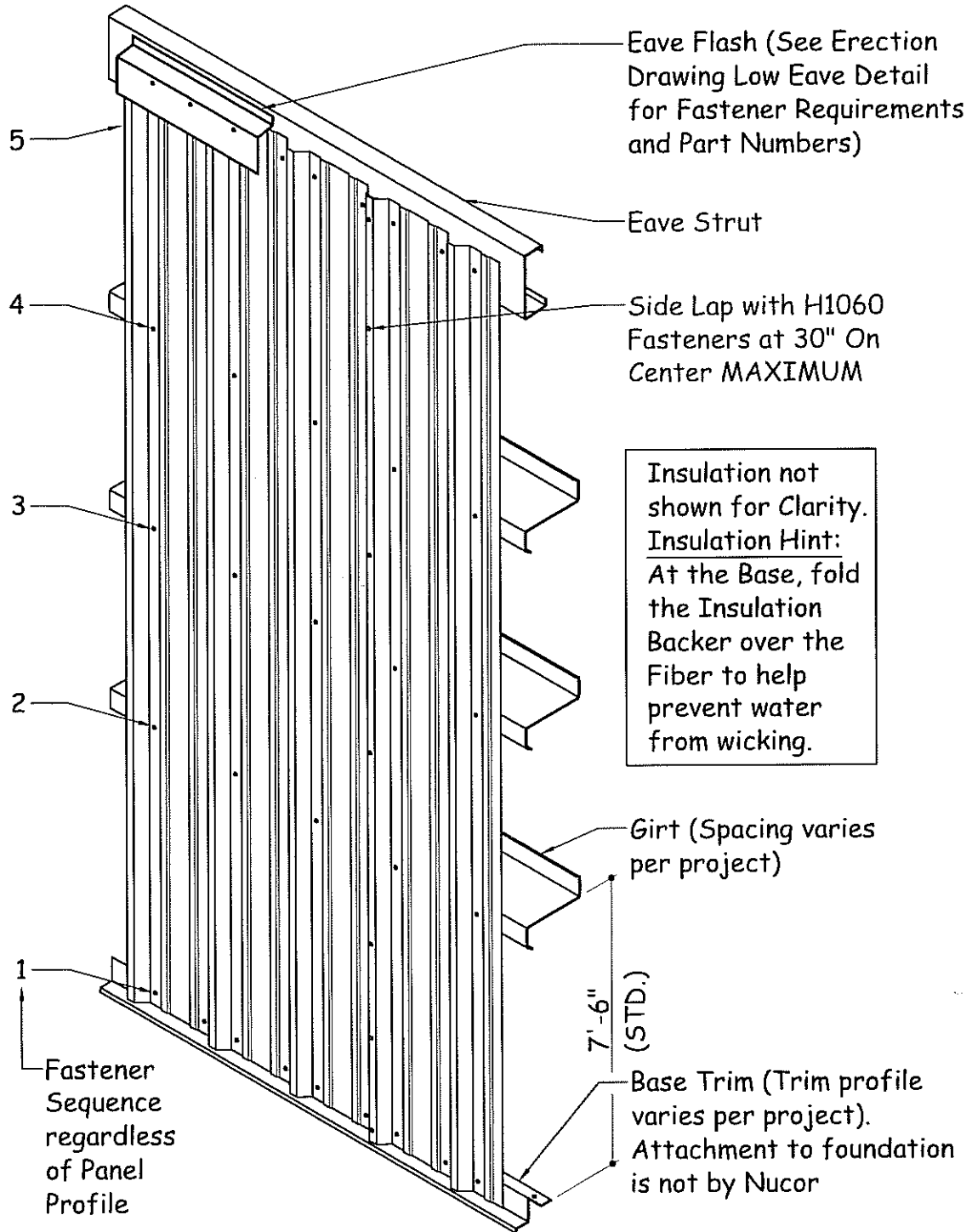

**NOTE:** "CLASSIC" Profile shown. Refer to Sections 7.2 and 7.3 for Fastener quantity requirements for "ACCENT" and "REVERSE CLASSIC" profiles.



## 8.0 FRAMED OPENING TRIM INSTALLATION

### 8.1 PANEL PREPARATION AT HEAD TRIM

Make a diagonal cut in the wall panel as shown below. If the cut is made vertically, it increases the chance of potential leaks.

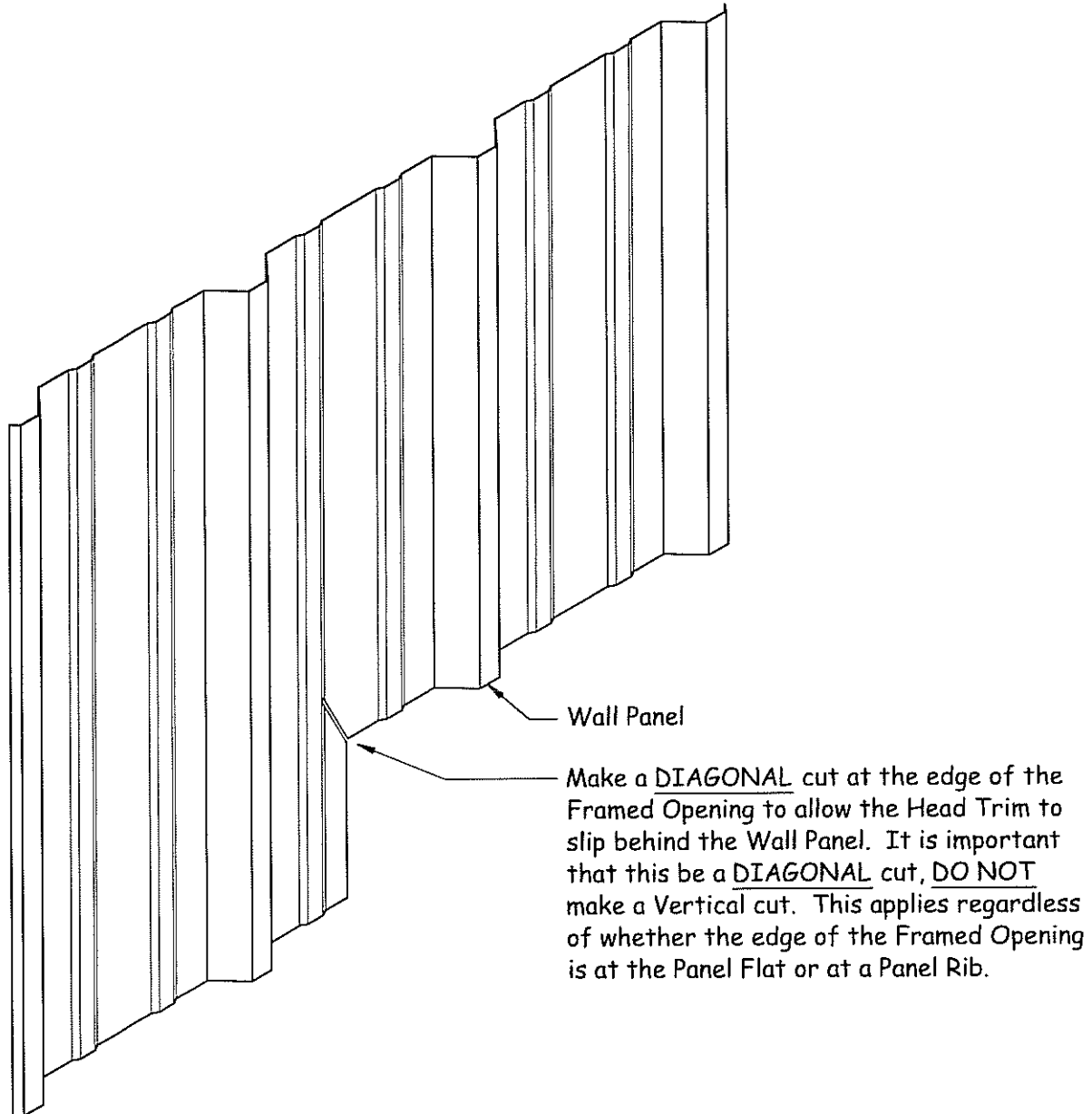

## 8.2 HEAD TRIM INSTALLATION

Slide the head trim into place and fasten at 12" on center with panel colored **self-drilling screws (H1040)** fasteners. See the erection

drawing sheeting elevations for head trim mark numbers.

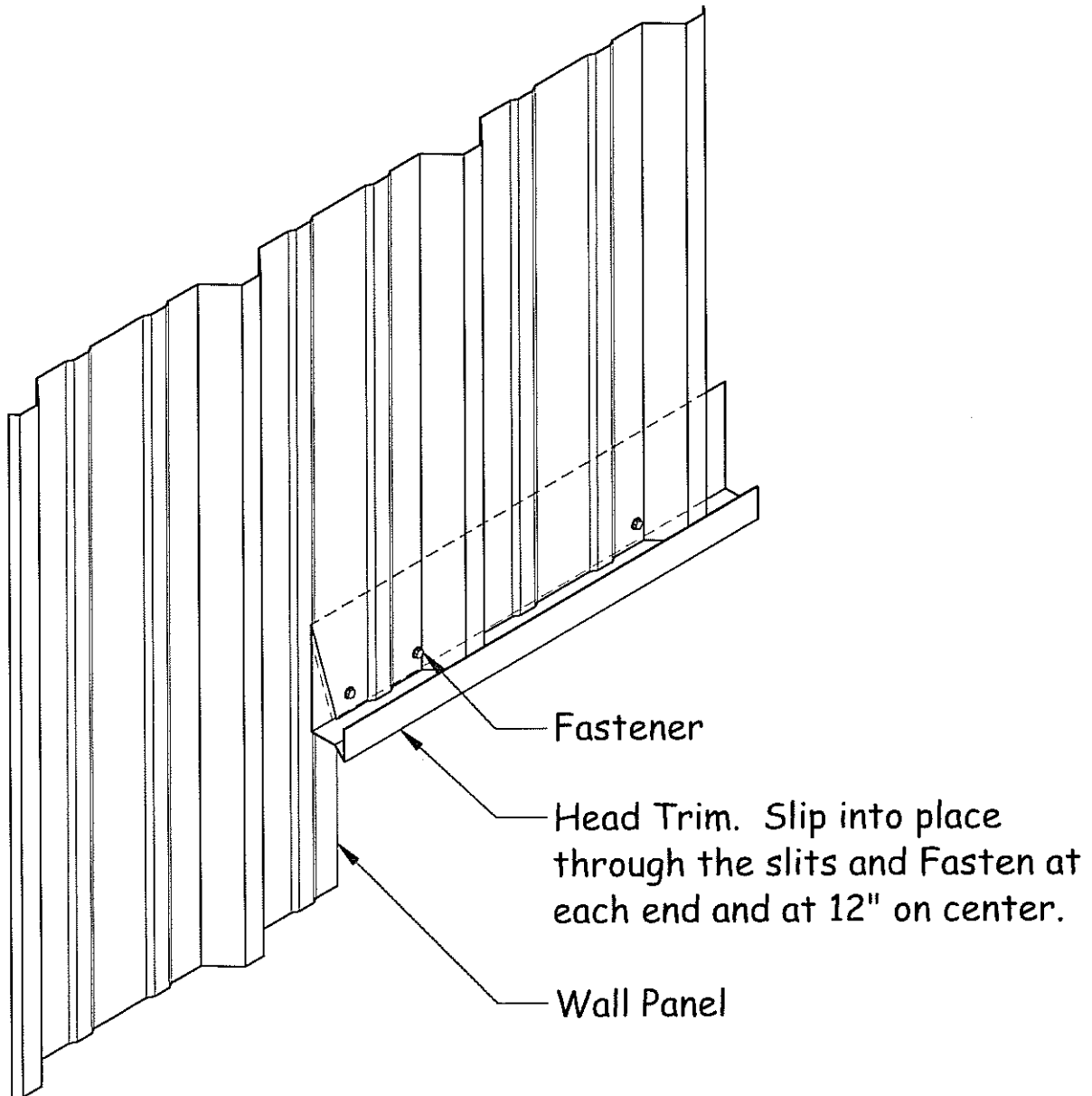

8.3 **STANDARD JAMB TRIM INSTALLATION**

Install the jamb trim after the head trim is installed. Fasten with panel colored **self-drilling screws (H1040)** at 12" on center. See the

erection drawing sheeting elevations for jamb trim mark numbers.

**NOTE:** The Top end of the Jamb Trim should butt against the Head Trim. **ALSO:** Be sure to install the Base Trim Plastic End Caps at Framed Openings (If your project utilizes Base Trim mark number BSB01).

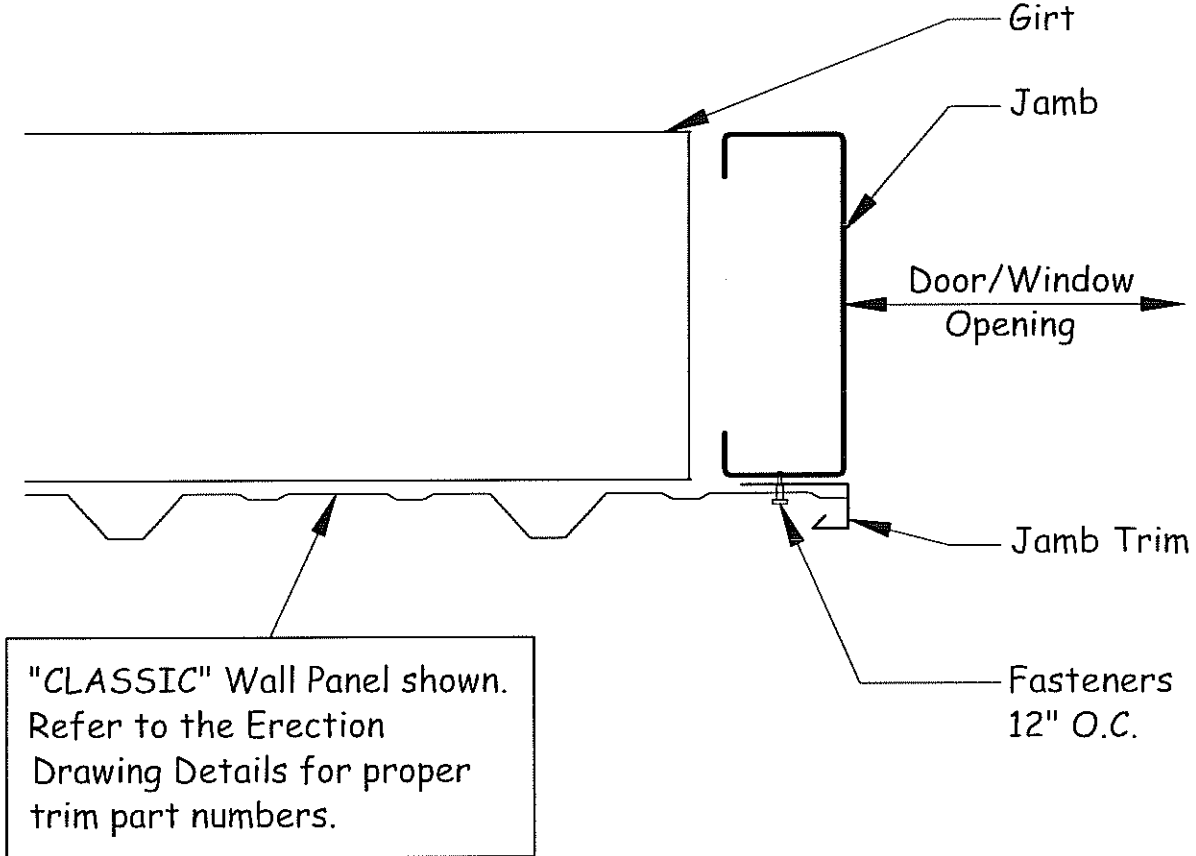

8.4 "REVERSE CLASSIC" PANEL JAMB TRIM INSTALLATION

installing the wall panel adjacent to the framed opening. This applies to both the "STANDARD" and "ALTERNATE" details below.

Install the Jamb Trim (See Erection Drawing Sheeting Elevations for Part Numbers) with self-drilling screws (H1040) at 12" on center before

STANDARD DETAIL AT PANEL FLAT

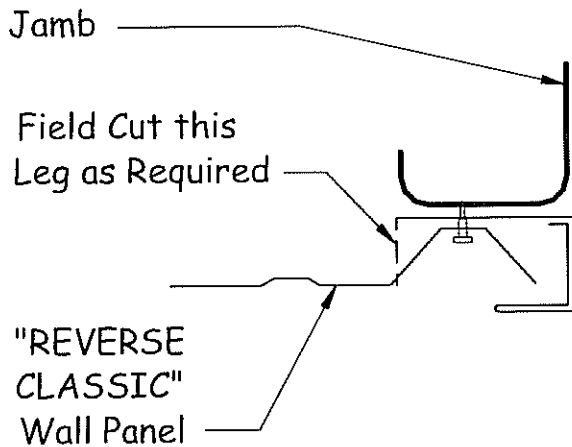
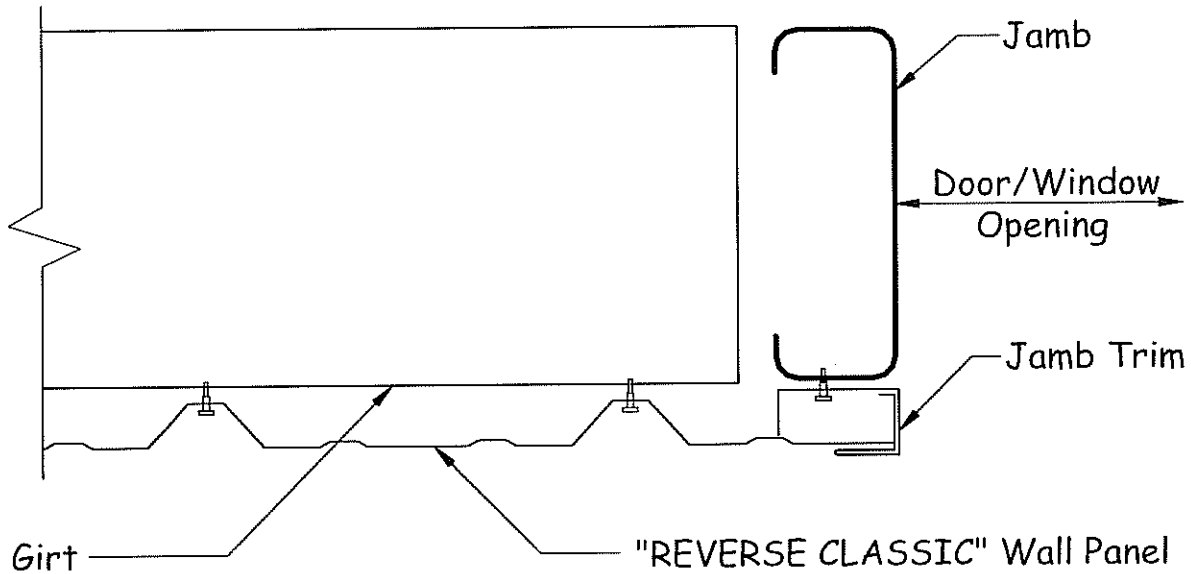

ALTERNATE DETAIL AT PANEL RIB

NOTE: If the Framed Opening is located at a Panel Rib, Use this Detail. The Jamb Trim will need to be field modified as shown.



## 9.0 CORNER TRIM INSTALLATION

### 9.1 "CLASSIC" PANEL

#### "CLASSIC" PANEL OUTSIDE CORNER DETAIL

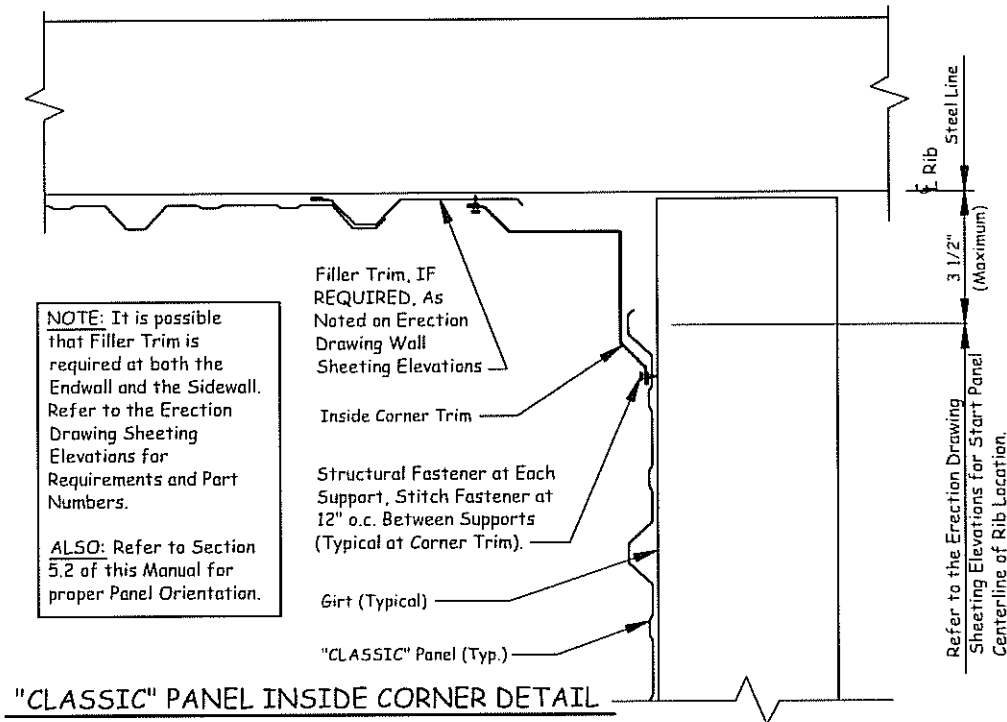
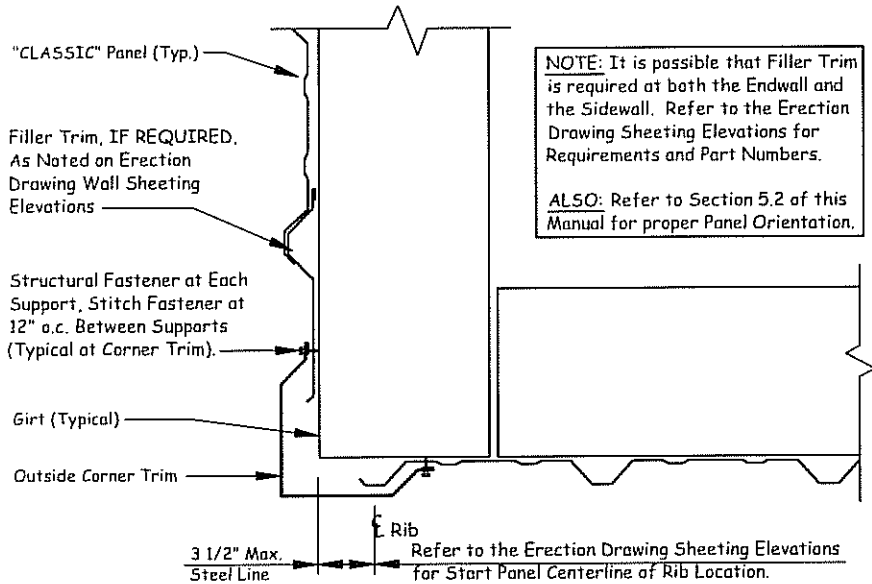

#### "CLASSIC" PANEL INSIDE CORNER DETAIL

9.2 "ACCENT" PANEL

"ACCENT" PANEL OUTSIDE CORNER DETAIL

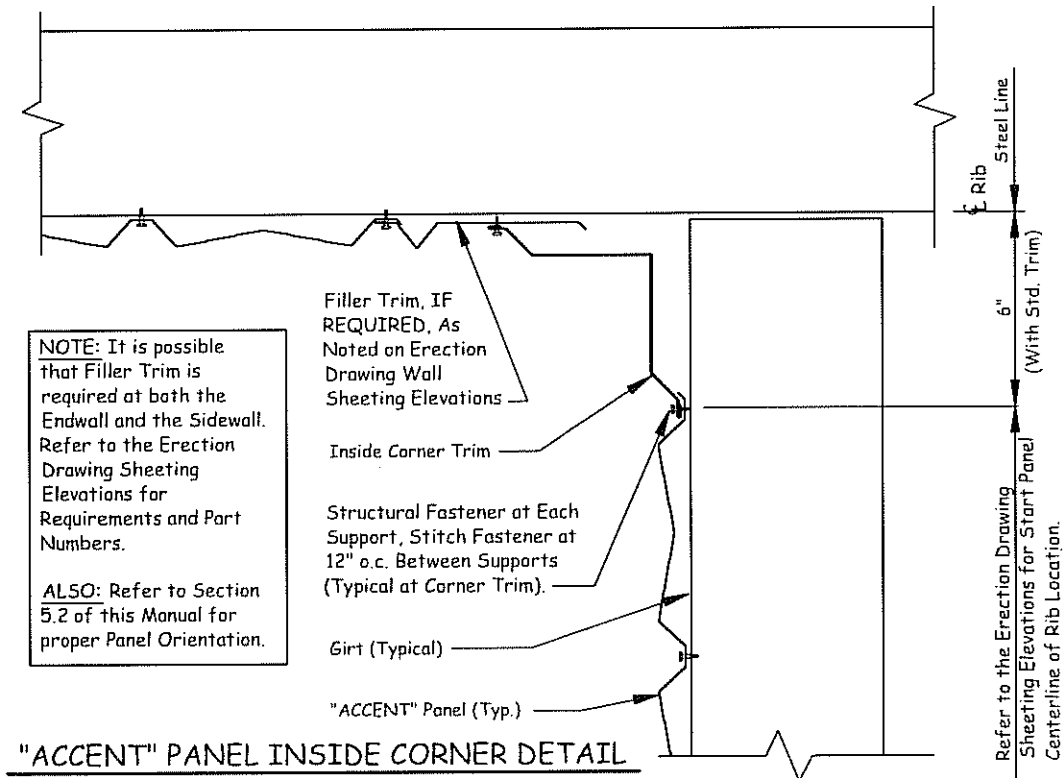
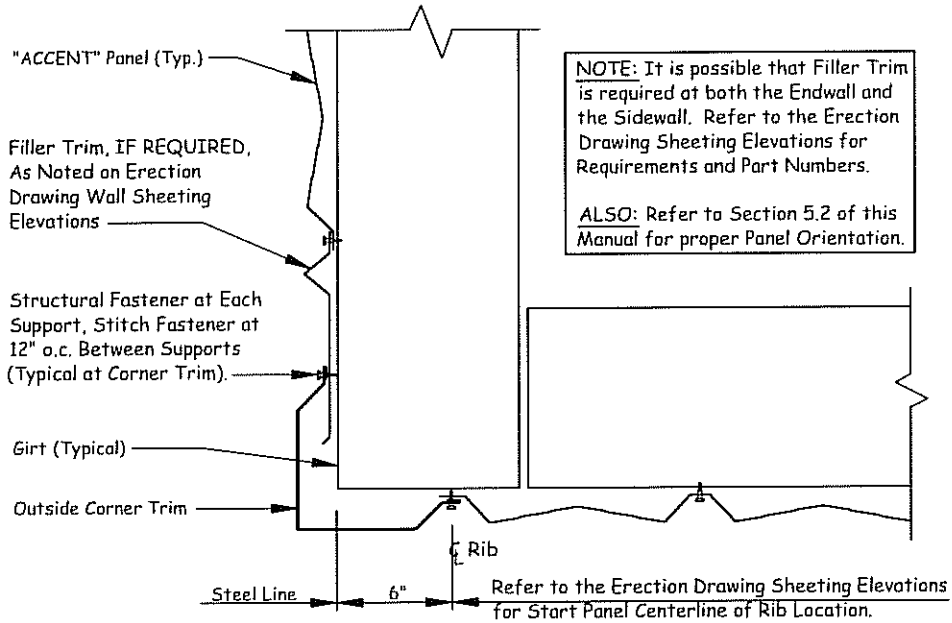

9.3 "REVERSE CLASSIC" PANEL

"REVERSE CLASSIC" PANEL OUTSIDE CORNER DETAIL

